

- 1
- 2
- 3
- 4
- 5
- 6
- 7
- 8
- 9
- 10
- 11
- 12
- 13
- 14
- 15
- 16
- 17
- 18
- 19

MAIN SPECIFICATIONS

- Die-cast zinc alloy **ZD**
- Epoxy resin coating
- Black, RAL 9005, textured finish **SW**
- Grey, RAL 9006, matte finish **SR**
- Hinge pin
- AISI 303 stainless steel
- Shim washers
- AISI 316L stainless steel
- Grub screws
- Stainless Steel AISI 304
- Spacer sleeves
- Polyamide based (PA) technopolymer
- Rubber inserts
- Elastomer (TPE)

FEATURES AND APPLICATIONS

Hinges GN 938 are used to fasten door panes, e.g. made of glass or plastic, so that they can rotate. They are designed to match the panel support clamp GN 939 (see page -).

The panels (door panes) are clamped between the rubber inserts and additionally secured with spacer sleeves, forming a positive connection.

If the hinges are used with profile systems with 6, 8 or 10 mm slots, T-nuts GN 938.1 (see page -) are available as mounting accessories. These make it easy to align the hinges and protect them from twisting.

The covers are supplied loose. They are slid on sideways after assembly and lock into place automatically.

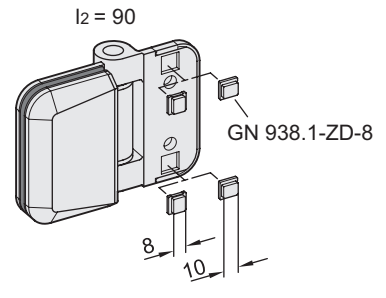
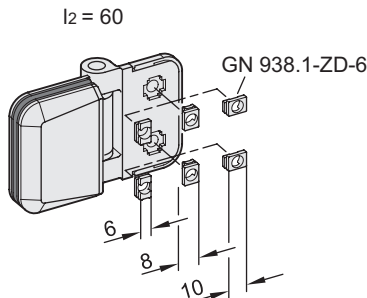
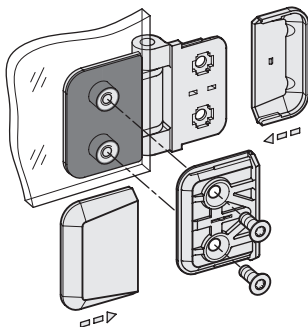
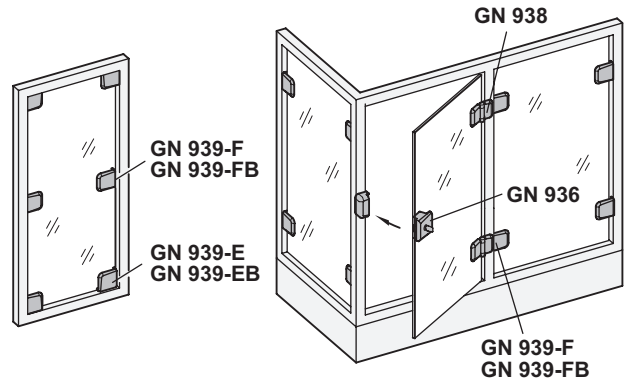
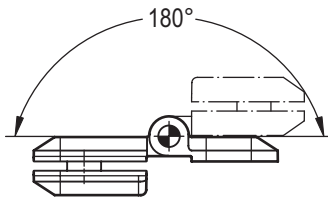

Hinges and accessories

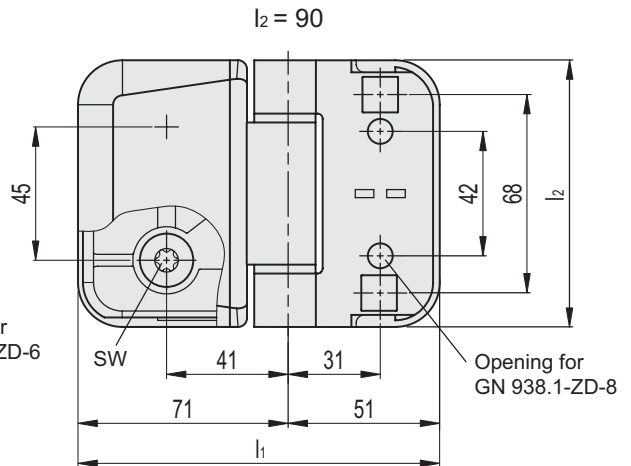
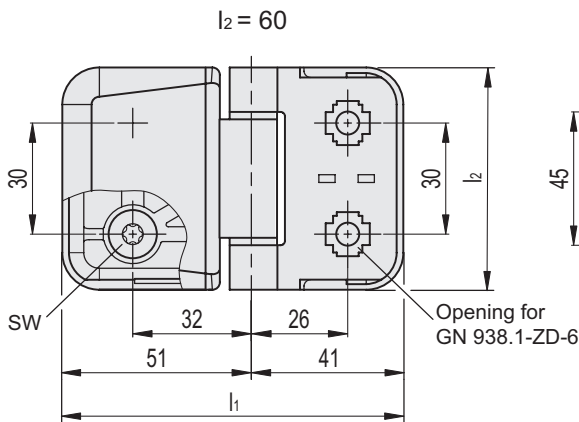
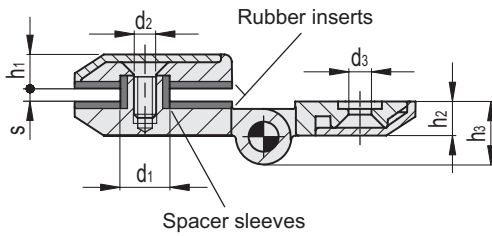
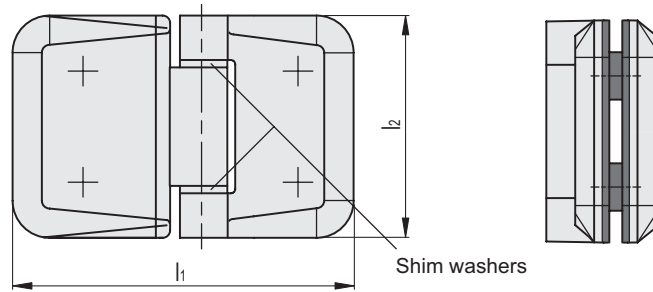

Code	Description	l1	l2	d1-0.2	d2 Clamping screw	d3 For screws	h1	h2	h3	s Nominal size	s Clamping range	sw	⚖
GN.70662	GN 938-ZD-92-60-4-SW	92	60	13	M 6	M 6	9.5	9.5	17	4	4 + 8	T30	360
GN.70661	GN 938-ZD-92-60-4-SR	92	60	13	M 6	M 6	9.5	9.5	17	4	4 + 8	T30	360
GN.70672	GN 938-ZD-122-90-8-SW	122	90	16	M 8	M 8	13.5	13.5	25	8	8 + 12	T45	1035
GN.70671	GN 938-ZD-122-90-8-SR	122	90	16	M 8	M 8	13.5	13.5	25	8	8 + 12	T45	1035